

## 16V, 2A Synchronous Buck Converter

### Description

The FDK1620 devices are synchronous step-down converters optimized for small solution size and high efficiency. The devices integrate switches capable of delivering an output current up to 2A. The devices are based on an adaptive on time with current mode control scheme. Typical operating frequency is 600 KHz at medium to heavy loads. The devices are optimized to achieve very low output voltage ripple even with small external components and feature an excellent load transient response. The low impedance internal MOSFET supports high efficiency operation with wide input voltage range from 4.5V to 16V. Power sequencing is possible by configuring the Enable pin. Other features like over current protection and over temperature protection are built-in. The FDK1620 devices are available in a SOT23-6 pin package.

### Features

- 4.5V to 16V Input Voltage Range
- 600KHz Typical Switching Frequency
- Output Current up to 2A (Max)
- Adaptive On Time Current Control
- 400 $\mu$ A Operating Quiescent Current
- Up to 93% Efficiency
- Over Current Protection
- Excellent Transient Load Response
- Internal Soft Startup of 300 $\mu$ s (Typ.)
- Thermal Shutdown Protection

### APPLICATIONS

- Portable TV
- LCD/OLED Monitors and TV
- DSL Modems
- IP CAM
- CCTV
- Set Top Boxes (STB)
- Networking

### TYPICAL APPLICATION

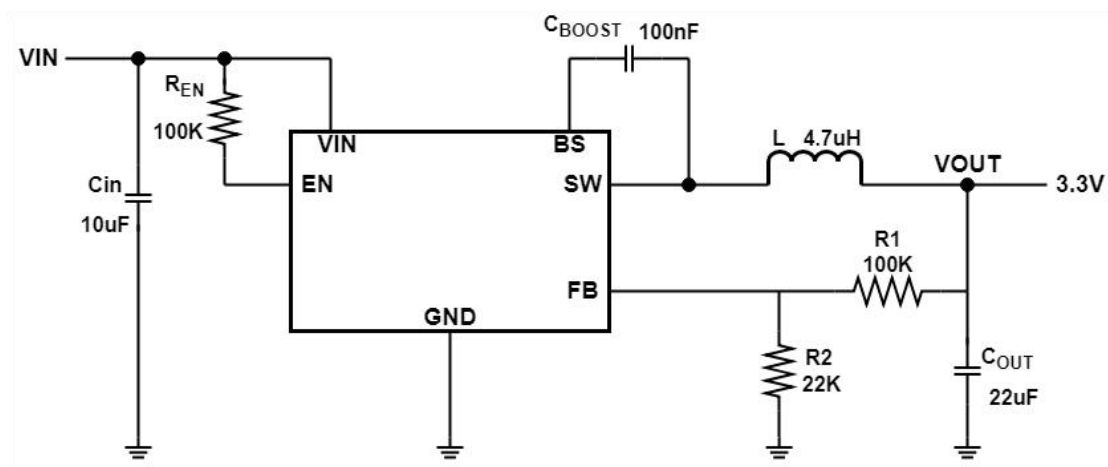

Figure 1. Typical Application for FDK1620

VOUT		R1	R2
$V_{OUT} = V_{FB} * (R1 + R2) / R2$	5.0V	100K	13.6K
	3.3V	100K	22K
	2.5V	68K	21.5K
	1.8V	43.2K	21.5K
	1.5V	33K	22K
	1.2V	22K	22K
	1.0V	15K	22K

## Order information

Mode	Package	Specified Temperature range	Ordering Number	Packing Option
FDK1620	SOT23-6	-40°C to +150°C	FDK1620YSOT236G/TR	Tape and Reel,5000

## PIN CONFIGURATION

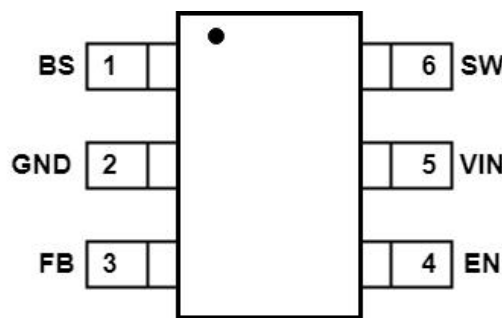

Figure 2. Pin Assignment of FDK1620 Package SOT23-6

## PIN DESCRIPTION

Pin Name	Pin No.	Pin Function
BS	1	Boot-Strap Pin. Supply high side gate driver. Connect a 22nF~100nF ceramic capacitor between the BS and LX pins.
GND	2	Ground
FB	3	Feedback pin for the internal control loop. Connect this pin to the external feedback divider.
EN	4	Device enable logic input. Logic HIGH enables the device. Logic LOW disables the device and turns it into shutdown. Do not leave floating.
VIN	5	Power supply voltage input.
SW	6	Feedback pin for the internal control loop. Connect this pin to the external feedback divider.

## Absolute Maximum Ratings

- VIN-----0.3V to +20V
- LX, EN-----0.3V to VIN+0.3V
- FB, BS-SW-----0.3V to +5V
- Junction Temperature -----125°C
- Lead Temperature (Soldering, 10 sec.) -----300°C
- Storage Temperature ----- -65°C to 150°C

## FUNCTIONAL Block Diagram

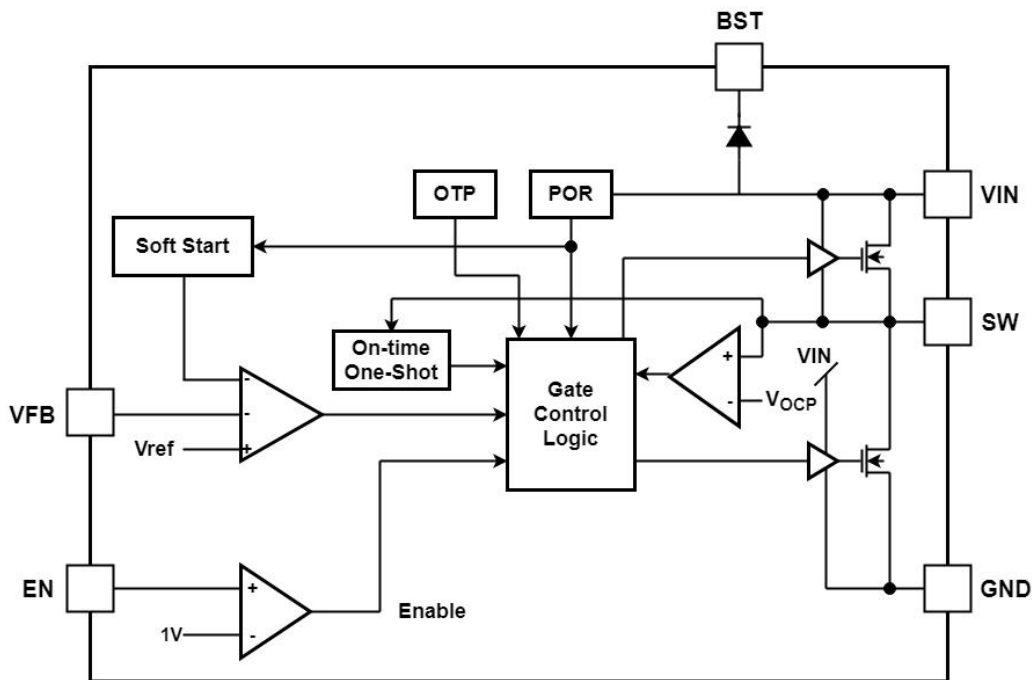

## ELECTRICAL CHARACTERISTICS

VIN=12V, VOUT = 1.2V, L = 2.2uH, COU T = 10uF, TJ=25°C, unless otherwise specified

Paramter	Symbol	Conditions	Min	Typ	Max	Unit
Input voltage	V <sub>IN</sub>		4.5		16	V
Quiescent current	I <sub>Q</sub>	I <sub>OUT</sub> = 0A, no switching	--	400	--	uA
Under voltage lock out	V <sub>UVLO</sub>	V <sub>IN</sub> rising	--	4.3	4.5	V
Under voltage lock out hysteresis	V <sub>UVLO_HY</sub>	V <sub>IN</sub> falling	--	0.15	--	V
EN high level voltage	V <sub>ENH</sub>		1.5	--	--	V
EN low level voltage	V <sub>ENL</sub>		--	--	0.4	V
Shutdown current	I <sub>SD</sub>	EN=LOW	--	5	10	uA
Output voltage	V <sub>OUT</sub>		0.6	--	D <sub>MAX</sub> *V <sub>IN</sub>	V
Feedback voltage	V <sub>FB</sub>		0.588	0.6	0.612	V
FB pin current	I <sub>FB</sub>	V <sub>FB</sub> = V <sub>IN</sub>	-50		50	nA

High-side switch resistance	$R_{DSONH}$	$V_{BS-LX} = 4.8V$	--	120	--	mΩ
Low-side switch resistance	$R_{DSONL}$	$V_{IN} = 5V$	--	100	--	mΩ
High-side switch peak current limit	$I_{LIM\_H}$		2.4			A
Switching frequency	$f_{SW}$		--	520	--	KHZ
Minimum ON-time	$t_{ONMIN}$		--	50	--	nS
Minimum OFF-time	$t_{OFFMIN}$		--	100	--	nS
Soft Start time	$t_{SS}$			300		uS
Thermal shutdown threshold	$T_{SDN}$		--	150	--	°C
Thermal Shutdown Hysteresis	$T_{SDNHY}$		--	30	--	°C

## TYPICAL PERFORMANCE CHARACTERISTICS

$V_{IN}=12V$ ,  $V_{OUT} = 3.3V$ ,  $L = 4.7\mu H$ ,  $C_{OUT} = 22\mu F$ ,  $T_J=25^\circ C$ , unless otherwise specified

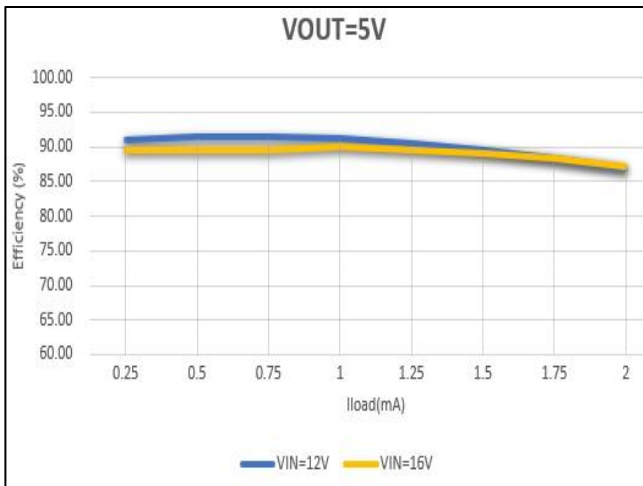

Fig 1 Efficiency vs Load

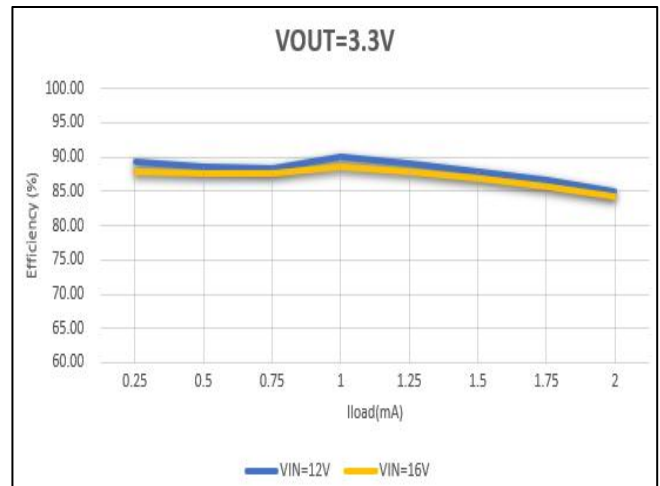

Fig 2 Efficiency vs Load

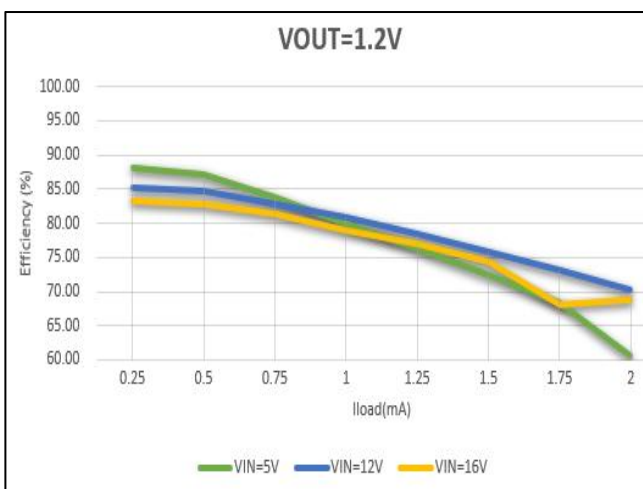

Fig 3 Efficiency vs Load

## Operating Waveforms

$V_{IN}=12V$ ,  $V_{OUT} = 3.3V$ ,  $L = 4.7\mu H$ ,  $C_{OUT} = 22\mu F$ ,  $T_J=25^\circ C$ , unless otherwise specified

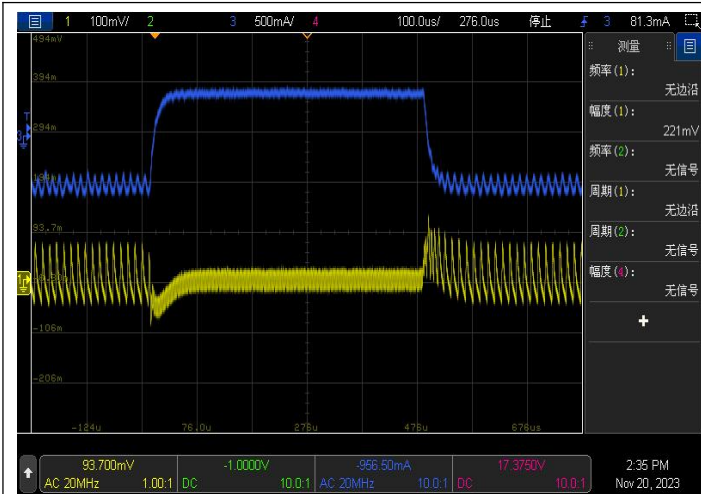

Fig 5 Load Transient ( $V_{in}=12V$ ,  $V_{out}=3.3V$ ,  $I_{LOAD}=0.1-1A$ )

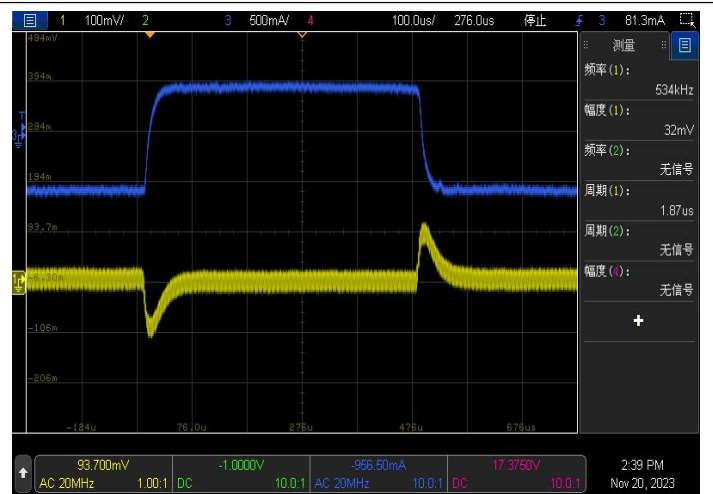

Fig 6 Load Transient ( $V_{in}=12V$ ,  $V_{out}=3.3V$ ,  $I_{LOAD}=1-2A$ )

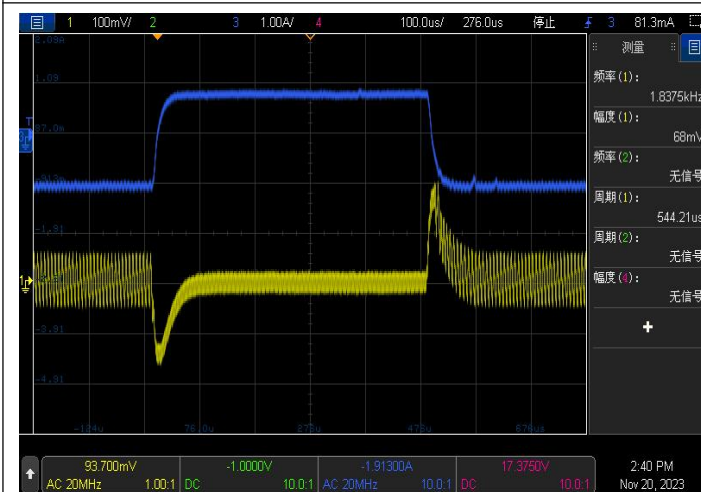

Fig 7 Load Transient ( $V_{in}=12V$ ,  $V_{out}=3.3V$ ,  $I_{LOAD}=0.2-2A$ )



Fig 8 Enable Start up ( $V_{in}=12V$ ,  $V_{out}=3.3V$ ,  $I_{LOAD}=2A$ )

CH1:  $V_{OUT}$ , 2V/Div, DC; CH2:  $V_{sw}$ , 5V/Div, DC

CH3:  $I_{OUT}$ , 2A/Div, DC; CH4: EN, 5V/Div, DC

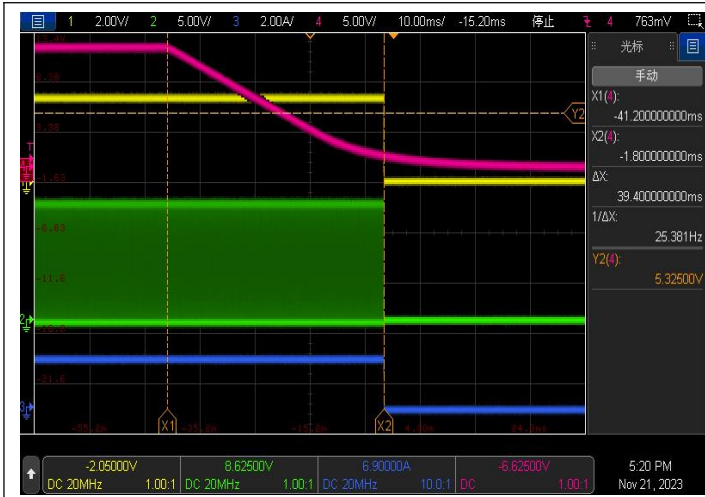

Fig 9 Shutdown ( $V_{in}=12V$ ,  $V_{out}=3.3V$ ,  $I_{LOAD}=2A$ )  
 CH1:  $V_{OUT}$ , 2V/Div, DC;  
 CH2:  $V_{sw}$ , 5V/Div, DC  
 CH3:  $I_{out}$ , 2A/Div, DC; CH4: EN, 5V/Div, DC

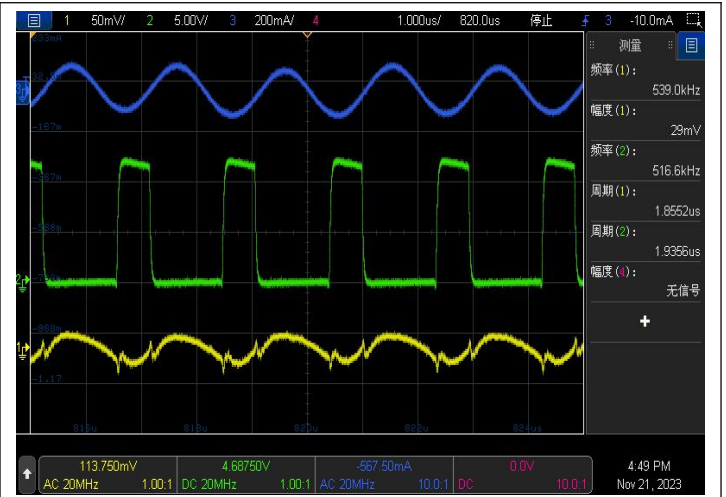
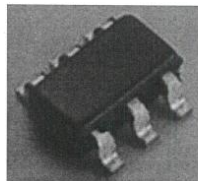
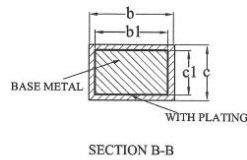
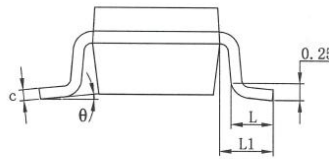
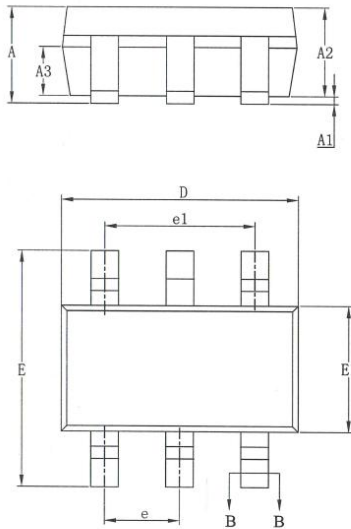

Fig 10 Output Ripple ( $V_{in}=12V$ ,  $V_{out}=3.3V$ ,  $I_{LOAD}=2A$ )  
 CH1:  $V_{OUT}$ , 50mV/Div, AC;  
 CH2:  $V_{sw}$ , 5V/Div, DC  
 CH3:  $I_{peak}$ , 200mA/Div, AC;

## Package Outline Dimensions (All dimensions in mm.)

Package Type: SOT23-6



SYMBOL	MILLIMETER		
	MIN	NOM	MAX
A	—	—	1.25
A1	0.04	—	0.10
A2	1.00	1.10	1.20
A3	0.60	0.65	0.70
b	0.33	—	0.41
b1	0.32	0.35	0.38
c	0.15	—	0.19
c1	0.14	0.15	0.16
D	2.82	2.92	3.02
E	2.60	2.80	3.00
E1	1.50	1.60	1.70
e	0.95BSC		
e1	1.90BSC		
L	0.30	—	0.60
L1	0.60REF		
theta	0	—	8°