

## Hex Buffer/Driver With Open-Drain Output

### Description

This hex buffer/driver is designed for 1.65-V to 5.5-V VCC operation.

The output of the FLG74LVC07A device is open drain and can be connected to other open-drain outputs to implement active-low wired-OR or active-high wired-AND functions.

The maximum sink current is 32 mA. Schmitt-trigger action at all inputs makes the circuit tolerant of slower input rise and fall times.

The FLG74LVC07A is available in a variety of packages, including the SO14/TSSOP14 package with a body size of 8.65mmX6mm & 5mm × 4.4mm.

### Features

- Inputs Accept Voltages 1.65V to 5.5 V
- Max Tpd of 4.2 ns at 3.3 V
- Low Power Consumption, 10-  $\mu$  A Max  $I_{CC}$
- $\pm 24$ -mA Output Drive at 3.3 V
- Latch-Up Performance Exceeds 100 mA Per JESD 78, Class II
- ESD Protection Exceeds JESD 22
  - 2000-V Human-Body Model (A114-A)
  - 1000-V Charged-Device Model (C101)

### Applications

- AV Receiver
- Server
- Network Switches
- Embedded PC
- Software Defined Radio (SDR)
- I/O Expanders
- Base Station Processor Board
- Solid State Drive (SSD): Enterprise
- High-Definition (HDTV)
- Tablet: Enterprise
- Audio Dock: Portable
- DLP Front Projection Systems
- DVR and DVS
- Digital Picture Frame (DPF)
- Digital Still Cameras

## Order information

Mode	Package	Ordering Number	Packing Option
FLG74LVC07A	SO14	FLG74LVC07AYSOP14G/TR	Tape and Reel,2500
	TSSOP14	FLG74LVC07AYTSSOP14G/TR	Tape and Reel,2500

## Pin Configuration

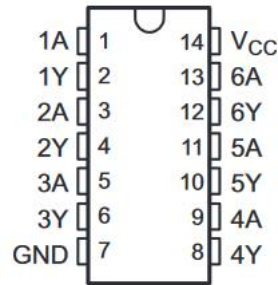

SO14 / TSSOP14

## Simplified Schematic

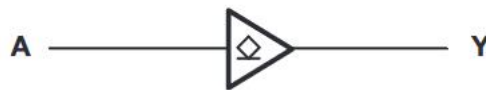

## Pin Assignment

Pin Name	Pin No.	Pin No.	Pin Function
1A	1	I	Channel 1 Data Input
1Y	2	O	Channel 1 Data Output
2A	3	I	Channel 2 Data Input
2Y	4	O	Channel 2 Data Output
3A	5	I	Channel 3 Data Input
3Y	6	O	Channel 3 Data Output
GND	7	Ground	Ground
4A	8	I	Channel 4 Data Input
4Y	9	I	Channel 4 Data Output
5A	10	O	Channel 5 Data Input
5Y	11	I	Channel 5 Data Output
6A	12	I	Channel 6 Data Input
6Y	13	O	Channel 6 Data Output
VCC	14	Power	Positive Supply

## Absolute Maximum Ratings (Note1)

- $V_{CC}$  ----- -0.5V to +6.5V
- $V_I$  ----- -0.5V to +6.5V
- $V_O$  (Voltage range applied to any output in the high-impedance or power-off state) ----- -0.5V to +6.5V
- $V_O$  (Voltage range applied to any output in the high or low state) ----- -0.5V to  $V_{CC}+0.5V$
- Input clamp current ----- -50mA
- Output clamp current ----- -50mA
- Continuous output current -----  $\pm 50mA$
- Storage Temperature -----  $-65^{\circ}C$  to  $150^{\circ}C$

## Recommended Operating Conditions

Parameter	Symbol	Test Conditions	Min	Typ	Max	Units
Supply voltage	$V_{CC}$	Operating	1.65		5.5	V
		Data retention only	1.5			
Input voltage	$V_I$		0		5.5	V
Output voltage	$V_O$				$V_{CC}$	V
High- level input voltage	$V_{IH}$	$V_{CC} = 1.65V$ to $1.95V$	$0.65 \times V_{CC}$			V
		$V_{CC} = 2.3V$ to $2.7V$	1.7			
		$V_{CC} = 3V$ to $3.6V$	2			
		$V_{CC} = 4.5V$ to $5.5V$	$0.7 \times V_{CC}$			
Low- level input voltage	$V_{IL}$	$V_{CC} = 1.65V$ to $1.95V$			$0.35 \times V_{CC}$	V
		$V_{CC} = 2.3V$ to $2.7V$			0.7	
		$V_{CC} = 3V$ to $3.6V$			0.8	
		$V_{CC} = 4.5V$ to $5.5V$			$0.3 \times V_{CC}$	
Low- level output current	$I_{OL}$	$V_{CC} = 1.65V$			4	mA
		$V_{CC} = 2.3V$			8	
		$V_{CC} = 3V$			16	
		$V_{CC} = 3V$			24	
		$V_{CC} = 4.5V$			32	
Input transition rise or fall rate	$\Delta T/\Delta V$	$V_{CC} = 1.8V \pm 0.15V, 2.5V \pm 0.2V$			20	ns/V
		$V_{CC} = 3.3V \pm 0.3V$			10	
		$V_{CC} = 5V \pm 0.5V$			5	
Operating temperature	$T_A$		-40		125	$^{\circ}C$

## Electrical Characteristics

Parameter	Symbol	Test Conditions	Min.	Typ.	Max.	Unit
Low- level output voltage	$V_{OL}$	$V_{CC} = 1.65 \sim 5.5V, I_{OL} = 100\mu A$			0.1	V
		$V_{CC} = 1.65V, I_{OL} = 4mA$			0.45	
		$V_{CC} = 2.3V, I_{OL} = 8mA$			0.3	
		$V_{CC} = 3V, I_{OL} = 16mA$			0.4	
		$V_{CC} = 3V, I_{OL} = 24mA$			0.55	
		$V_{CC} = 4.5V, I_{OL} = 32mA$			0.55	
Input leakage current	$I_I$	$V_{IN} = 5.5V$ or GND, $V_{CC} = 0 \sim 5.5V$			$\pm 5$	$\mu A$
Power off leakage current	$I_{OFF}$	$V_I$ or $V_O = 5.5V, V_{CC} = 0V$			$\pm 10$	$\mu A$
Supply current	$I_{CC}$	$V_{IN} = V_{CC}$ or GND, $I_{OUT} = 0, V_{CC} = 1.65 \sim 5.5V$			10	$\mu A$
Additional supply current per input pin	$\Delta I_{CC}$	$V_{CC} = 3 \sim 5.5V$ , one input at $V_{CC} - 0.6V$ , other input at $V_{CC}$ or GND			500	$\mu A$

## Switching Characteristics

Parameter	Symbol	Test Conditions	Min.	Typ.	Max.	Unit
Propagation delay from input(A or B) to output(Y)	$T_{PD}$	$V_{CC} = 1.8V \pm 0.15V, R_L = 1K\Omega$	2.4		8.3	ns
		$V_{CC} = 2.5V \pm 0.2V, R_L = 500\Omega$				
		$V_{CC} = 3.3V \pm 0.3V, R_L = 500\Omega$	1.5		4.2	
		$V_{CC} = 5V \pm 0.5V, R_L = 500\Omega$				

## Typical Characteristics

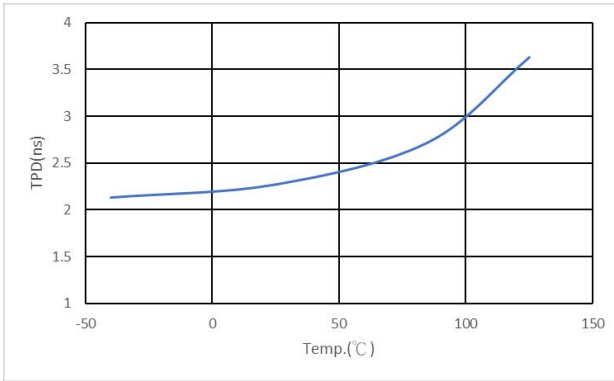

Fig.1 TPD across Temperature at 3.3V VCC

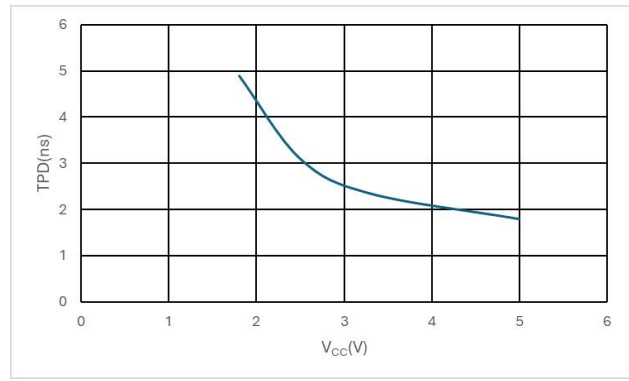
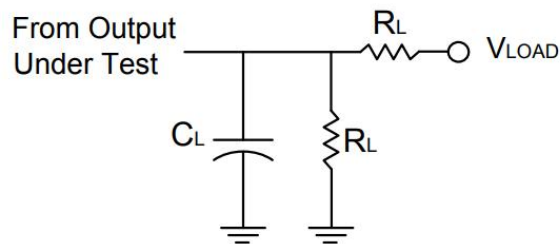

Fig.2 TPD across VCC at 25°C

## Parameter Measurement Information



TEST	Condition
t <sub>PLZ</sub>	V <sub>LOAD</sub>
t <sub>PZL</sub>	V <sub>LOAD</sub>

V <sub>CC</sub>	INPUTS		V <sub>M</sub>	V <sub>LOAD</sub>	C <sub>L</sub>	R <sub>L</sub>	V $\Delta$
	V <sub>I</sub>	t <sub>r</sub> /t <sub>f</sub>					
1.8V $\pm$ 0.15V	V <sub>CC</sub>	$\cong$ 2ns	V <sub>CC</sub> /2	2 $\times$ V <sub>CC</sub>	30pF	1k $\Omega$	0.15V
2.5V $\pm$ 0.2V	V <sub>CC</sub>	$\cong$ 2ns	V <sub>CC</sub> /2	2 $\times$ V <sub>CC</sub>	30pF	500 $\Omega$	0.15V
3.3V $\pm$ 0.3V	3V	$\cong$ 2.5ns	1.5V	6V	50pF	500 $\Omega$	0.3V
5V $\pm$ 0.5V	V <sub>CC</sub>	$\cong$ 2.5ns	V <sub>CC</sub> /2	2 $\times$ V <sub>CC</sub>	50pF	500 $\Omega$	0.3V

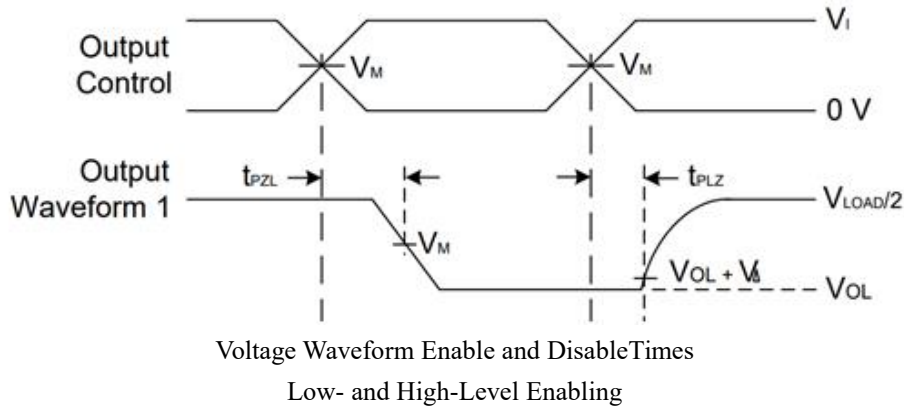

- Notes:
- A.  $C_L$  includes probe and jig capacitance
  - B. All pulses are supplied at pulse repetition rate  $\cong 10\text{MHz}$
  - C. The Inputs are measured one at a time with one transition per measurement
  - D. For the open drain device  $t_{PLZ}$  and  $t_{PZL}$  are the same as  $t_{PD}$
  - E.  $t_{PZL}$  is measured at  $V_M$
  - F.  $t_{PLZ}$  is measured at  $V_{OL} + V_{\Delta}$

## IC Operation Information

### Basic Operation

The FLG74LVC07A device contains six open-drain buffers with a maximum sink current 32mA. This device is fully specified for partial-power-down applications using Ioff. The Ioff circuitry disables the outputs, preventing damaging current backflow through the device when it is powered down. The SO14/TSSOP14 package technology is a major breakthrough in IC packaging.

### Function Block Diagram

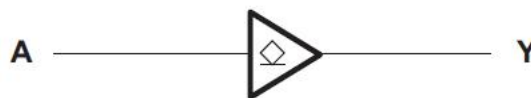

### Feature Description

- Wide operating voltage range.
  - Operates from 1.65 V to 5.5 V.
- Allows down voltage translation.
- Inputs accept voltages to 5.5 V.
- Ioff feature allows voltages on the inputs and outputs when  $V_{CC}$  is 0 V.

## Device Functional Table

INPUT	OUTPUT
A	Y
L	L
H	Z

## IC Application Information

The FLG74LVC07A is a high drive CMOS device that can be used to implement a high output drive buffer, such as an LED application. It can produce 32 mA of drive current at 4.5 V making it Ideal for driving multiple outputs and good for high speed applications up to 100 MHz. The inputs are 5.5 V tolerant allowing it to translate down to VCC.

## Typical Application

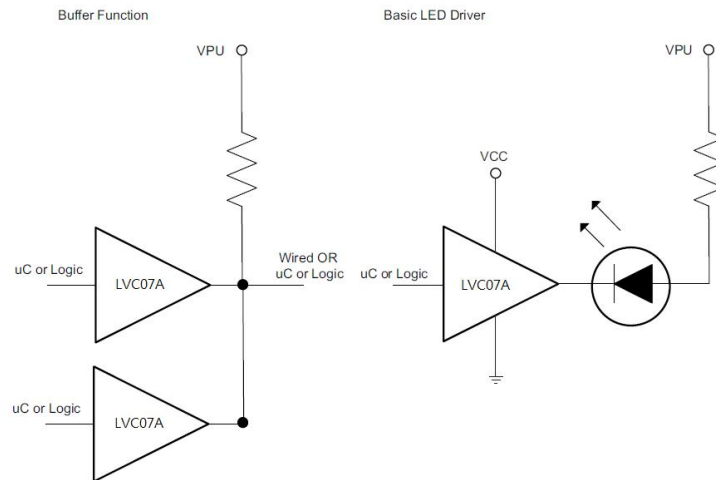

## Design Requirements

This device uses CMOS technology and has balanced output drive. Care should be taken to avoid bus contention because it can drive currents that would exceed maximum limits. The high drive will also create fast edges into light loads so routing and load conditions should be considered to prevent ringing.

## Detailed Design Procedure

### 1. Recommended Input Conditions

- Rise time and fall time specs. See ( $\Delta t / \Delta V$ ) in the Recommended Operating Conditions table.
- Specified high and low levels. See ( $V_{IH}$  and  $V_{IL}$ ) in the Recommended Operating Conditions table
- Inputs are overvoltage tolerant allowing them to go as high as ( $V_{I max}$ ) in the Recommended Operating Conditions table at any valid  $V_{CC}$ .

### 2. Recommend Output Conditions

- Load currents should not exceed ( $I_{O max}$ ) per output and should not exceed total current (continuous current

through  $V_{CC}$  or GND) for the part. These limits are located in the Absolute Maximum Ratings table.

– Outputs should not be pulled above  $V_{CC}$ .

## Application Curves

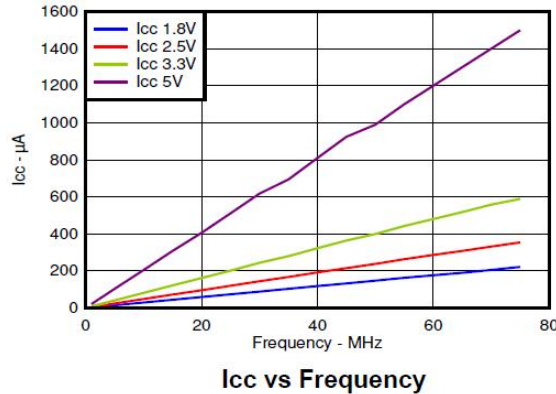

## Power Supply Recommendations

The power supply can be any voltage between the min and max supply voltage rating located in the Recommended Operating Conditions table.

Each  $V_{CC}$  pin should have a good bypass capacitor to prevent power disturbance. For devices with a single supply, a 0.1- $\mu\text{F}$  capacitor is recommended and if there are multiple  $V_{CC}$  pins then 0.01- $\mu\text{F}$  or 0.022- $\mu\text{F}$  capacitor is recommended for each power pin. It is ok to parallel multiple bypass capacitors to reject different frequencies of noise. 0.1- $\mu\text{F}$  and 1- $\mu\text{F}$  capacitors are commonly used in parallel. The bypass capacitor should be installed as close to the power pin as possible for best results.

## Layout Considerations

When using multiple bit logic devices inputs should not ever float. In many cases, functions or parts of functions of digital logic devices are unused; for example, when only two inputs of a triple-input buffer gate are used or only 3 of the 4 buffer gates are used. Such input pins should not be left unconnected because the undefined voltages at the outside connections result in undefined operational states. Specified below are the rules that must be observed under all circumstances. All unused inputs of digital logic devices must be connected to a high or low bias to prevent them from floating. The logic level that should be applied to any particular unused input depends on the function of the device. Generally they will be tied to GND or  $V_{CC}$  whichever make more sense or is more convenient.

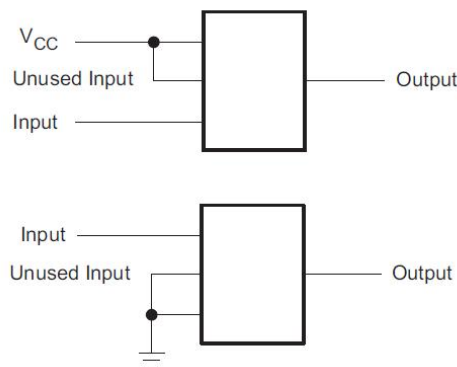

## Package Information

(1) Package Type: SO14

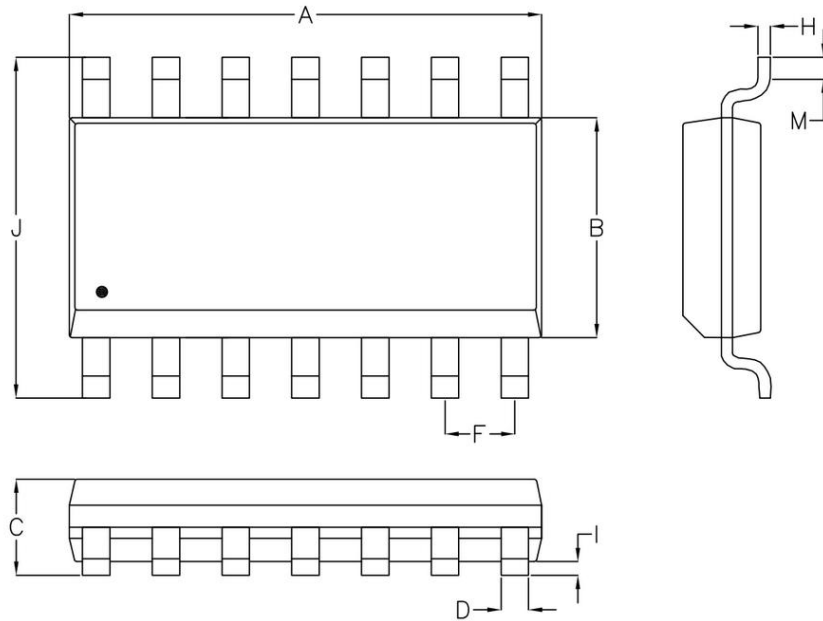

Symbol	Dimensions In Millimeters		Dimensions In Inches	
	Min.	Max.	Min.	Max.
A	8.534	8.738	0.336	0.344
B	3.810	3.988	0.150	0.157
C	1.346	1.753	0.053	0.069
D	0.330	0.508	0.013	0.020
F	1.194	1.346	0.047	0.053
H	0.178	0.254	0.007	0.010
I	0.102	0.254	0.004	0.010
J	5.791	6.198	0.228	0.244
M	0.406	1.270	0.016	0.050

(2) Package Type: TSSOP14

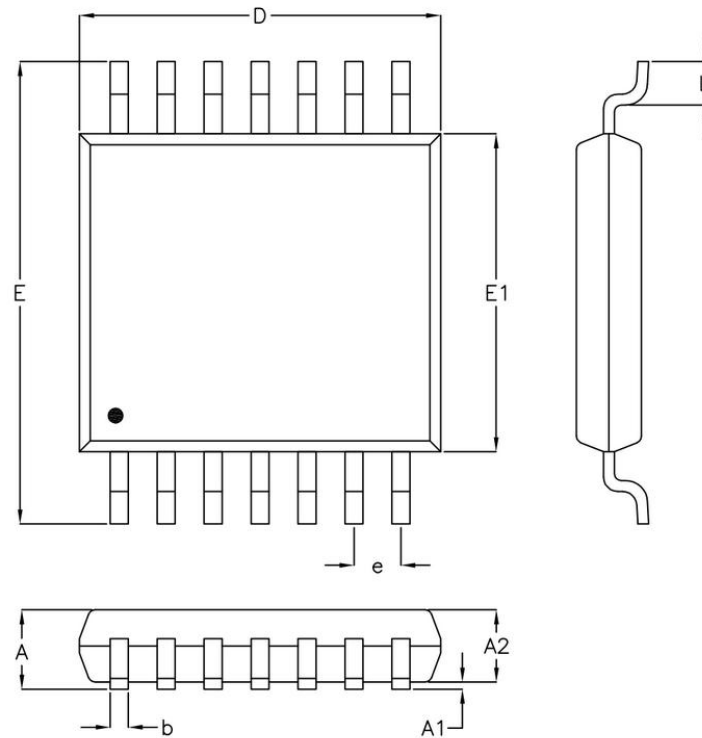

Symbol	Dimensions In Millimeters		Dimensions In Inches	
	Min.	Max.	Min.	Max.
A	1.000	1.200	0.039	0.047
A1	0.050	0.150	0.002	0.006
A2	0.800	1.050	0.031	0.041
b	0.190	0.300	0.007	0.012
D	4.900	5.100	0.193	0.201
e	0.650		0.026	
E	6.300	6.500	0.248	0.256
E1	4.300	4.500	0.169	0.177
L	0.450	0.750	0.018	0.030

## Important Notice And Disclaimer

- We reserves the right to change the instruction manual without prior notice.
- Any semiconductor product has a certain possibility of failure or malfunction under specific conditions. The buyer is responsible for complying with safety standards and taking safety measures when using our products for system design and overall manufacturing to avoid potential failure risks that may cause personal injury or property damage.
- The improvement of product quality is endless, our company will be dedicated to provide customers with better products.