

Single 2-Input Positive Exclusive-OR Gate

Description

This single 2-input exclusive-OR gate is designed for 1.65-V to 5.5-V VCC operation. The CMOS device provides high output drive while maintaining low static power consumption.

The FLG74LVC1G86 performs the Boolean function $Y = \overline{A}B + A\overline{B}$ in positive logic.

Schmitt-trigger action at all inputs makes the circuit tolerant of slower input rise and fall times.

The FLG74LVC1G86 is available in a variety of packages, including SOT-23-5, SC70.

Features

- Inputs Accept Voltages 1.65V to 5.5 V
- Max Tpd of 4 ns at 3.3 V
- Low Power Consumption, 10- μ A Max I_{CC}
- ± 24 -mA Output Drive at 3.3 V
- Latch-Up Performance Exceeds 100 mA Per JESD 78, Class II
- ESD Protection Exceeds JESD 22

- 2000-V Human-Body Model (A114-A)
- 1000-V Charged-Device Model (C101)

Applications

- AV Receiver
- Audio Dock: Portable
- Blu-ray Player and Home Theater
- Embedded PC
- MP3 Player/Recorder (Portable Audio)
- Personal Digital Assistant (PDA)
- Power: Telecom/Server AC/DC Supply: Single Controller: Analog and Digital
- Solid State Drive (SSD): Client and Enterprise
- TV: LCD/Digital and High-Definition (HDTV)
- Tablet: Enterprise
- Video Analytics: Server
- Wireless Headset, Keyboard, and Mouse
- Motor Drives and controls

Order information

Mode	Package	Ordering Number	Packing Option
FLG74LVC1G86	SOT23-5	FLG74LVC1G86YSOT235G/TR	Tape and Reel,3000
	SC70	FLG74LVC1G86YSC70G/TR	Tape and Reel,3000

Pin Configuration

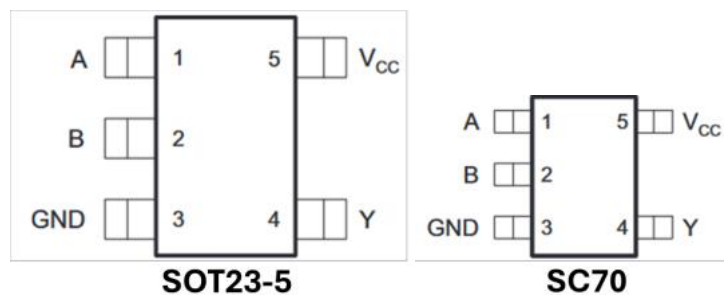

Simplified Schematic



Pin Assignment

Pin Name	Pin No.	Pin Function
A	1	Input
B	2	Input
GND	3	Ground
Y	4	Output
VCC	5	Power Pin

Absolute Maximum Ratings (Note1)

- V_{CC} ----- -0.5V to +6.5V
- V_I ----- -0.5V to +6.5V
- V_O (Voltage range applied to any output in the high-impedance or power-off state) ----- -0.5V to +6.5V
- V_O (Voltage range applied to any output in the high or slow state) ----- -0.5V to $V_{CC}+0.5V$
- Input clamp current ----- -50mA
- Output clamp current ----- -50mA
- Continuous output current ----- $\pm 50mA$
- Storage Temperature ----- $-65^{\circ}C$ to $150^{\circ}C$

Recommended Operating Conditions

Parameter	Symbol	Test Conditions	Min	Typ	Max	Units
Supply voltage	V_{CC}	Operating	1.65		5.5	V
		Data retention only	1.5			
Input voltage	V_I		0		5.5	V
Output voltage	V_O				V_{CC}	V
High- level input voltage	V_{IH}	$V_{CC} = 1.65V$ to $1.95V$	$0.65 \times V_{CC}$			V
		$V_{CC} = 2.3V$ to $2.7V$	1.7			
		$V_{CC} = 3V$ to $3.6V$	2			
		$V_{CC} = 4.5V$ to $5.5V$	$0.7 \times V_{CC}$			
Low- level input voltage	V_{IL}	$V_{CC} = 1.65V$ to $1.95V$			$0.35 \times V_{CC}$	V
		$V_{CC} = 2.3V$ to $2.7V$			0.7	
		$V_{CC} = 3V$ to $3.6V$			0.8	
		$V_{CC} = 4.5V$ to $5.5V$			$0.3 \times V_{CC}$	
High- level output current	I_{OH}	$V_{CC} = 1.65V$			-4	mA
		$V_{CC} = 2.3V$			-8	
		$V_{CC} = 3V$			-16	
		$V_{CC} = 3V$			-24	
		$V_{CC} = 4.5V$			-32	
Low- level output current	I_{OL}	$V_{CC} = 1.65V$			4	mA
		$V_{CC} = 2.3V$			8	
		$V_{CC} = 3V$			16	
		$V_{CC} = 3V$			24	
		$V_{CC} = 4.5V$			32	
Input transition rise or fall rate	$\Delta T/\Delta V$	$V_{CC} = 1.8V \pm 0.15V, 2.5V \pm 0.2V$			20	ns/V
		$V_{CC} = 3.3V \pm 0.3V$			10	
		$V_{CC} = 5V \pm 0.5V$			5	
Operating temperature	T_A		-40		125	$^{\circ}C$

Electrical Characteristics

Parameter	Symbol	Test Conditions	Min.	Typ.	Max.	Unit
High- level output voltage	V_{OH}	$V_{CC} = 1.65\sim 5.5V, I_{OH} = -100\mu A$	$V_{CC}-0.1$			V
		$V_{CC} = 1.65V, I_{OH} = -4mA$	1.2			
		$V_{CC} = 2.3V, I_{OH} = -8mA$	1.9			
		$V_{CC} = 3V, I_{OH} = -16mA$	2.4			
		$V_{CC} = 3V, I_{OH} = -24mA$	2.3			
		$V_{CC} = 4.5V, I_{OH} = -32mA$	3.8			
Low- level output voltage	V_{OL}	$V_{CC} = 1.65\sim 5.5V, I_{OL} = 100\mu A$			0.1	V
		$V_{CC} = 1.65V, I_{OL} = 4mA$			0.45	
		$V_{CC} = 2.3V, I_{OL} = 8mA$			0.3	
		$V_{CC} = 3V, I_{OL} = 16mA$			0.4	
		$V_{CC} = 3V, I_{OL} = 24mA$			0.55	
		$V_{CC} = 4.5V, I_{OL} = 32mA$			0.55	
Input leakage current	I_I	$V_{IN} = 5.5V$ or GND, $V_{CC} = 0\sim 5.5V$			± 5	μA
Power off leakage current	I_{OFF}	V_I or $V_O = 5.5V, V_{CC} = 0V$			± 10	μA
Supply current	I_{CC}	$V_{IN} = V_{CC}$ or GND, $I_{OUT} = 0, V_{CC} = 1.65\sim 5.5V$			10	μA
Additional supply current per input pin	ΔI_{CC}	$V_{CC} = 3\sim 5.5V$, one input at $V_{CC} - 0.6V$, other input at V_{CC} or GND			500	μA

Switching Characteristics

Parameter	Symbol	Test Conditions	Min.	Typ.	Max.	Unit
Propagation delay from input(A or B) to output(Y)	T_{PD}	$V_{CC} = 1.8V \pm 0.15V$	$C_L = 15pF$ $R_L = 1M\Omega$			ns
		$V_{CC} = 2.5V \pm 0.2V$				
		$V_{CC} = 3.3V \pm 0.3V$				
		$V_{CC} = 5V \pm 0.5V$				

Typical Characteristics

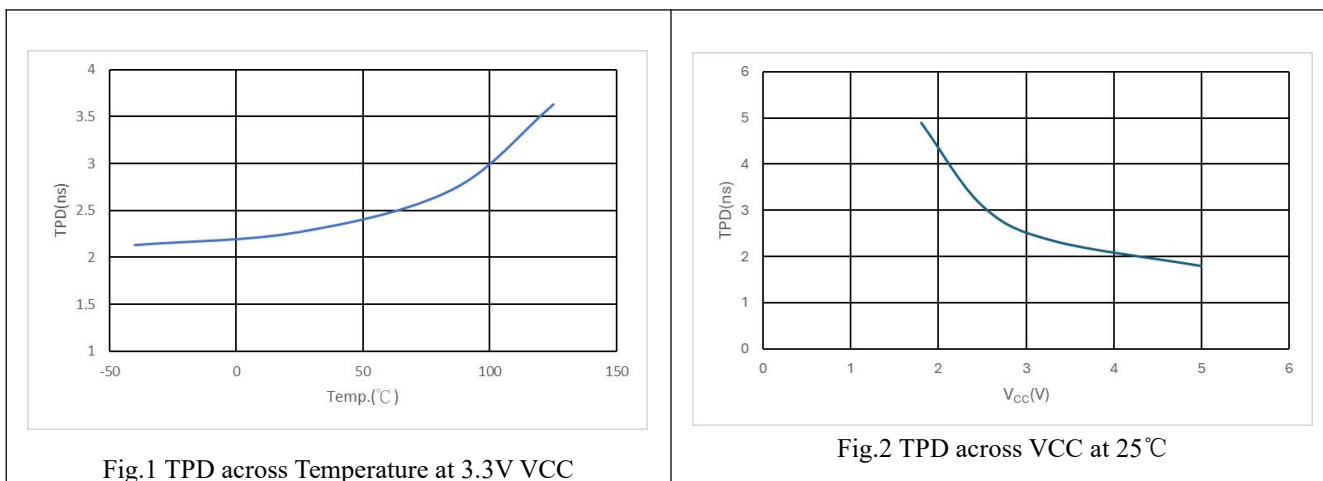

Parameter Measurement Information

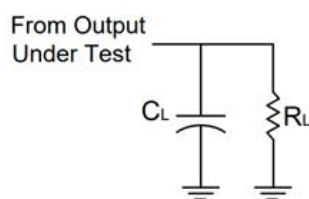

V _{CC}	INPUTS		V _M	C _L	R _L
	V _I	t _r /t _f			
1.8V ± 0.15V	V _{CC}	≅ 2ns	V _{CC} /2	15pF	1MΩ
2.5V ± 0.2V	V _{CC}	≅ 2ns	V _{CC} /2	15pF	1MΩ
3.3V ± 0.3V	3V	≅ 2.5ns	1.5V	15pF	1MΩ
5V ± 0.5V	V _{CC}	≅ 2.5ns	V _{CC} /2	15pF	1MΩ

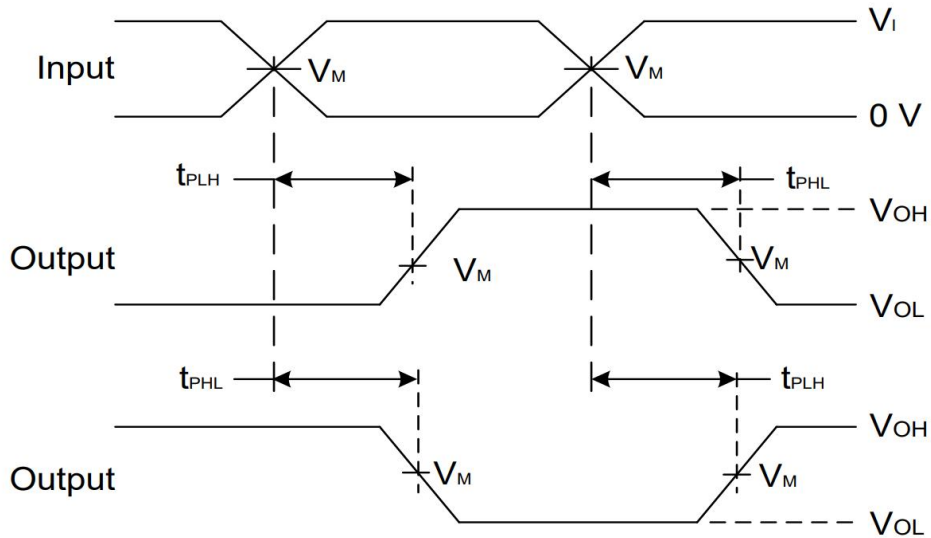

Voltage Waveform Propagation Delay Times
Inverting and Non Inverting Outputs

- Notes:
- A. C_L includes probe and jig capacitance
 - B. All pulses and supplied at pulse repetition rate $\cong 10\text{MHz}$
 - C. The Inputs are measured separately one transition per measurement
 - D. t_{PLH} and t_{PHL} are the same as t_{PD}
 - E. All parameters and waveforms are not applicable to all devices.

IC Operation Information

Basic Operation

The FLG74LVC1G86 device performs the Boolean function $Y = \overline{A}B + A\overline{B}$. This device is fully specified for partial-power-down applications using Ioff. The Ioff circuitry disables the outputs, preventing damaging current backflow through the device when it is powered down.

Function Block Diagram



Feature Description

- Wide operating voltage range.
 - Operates from 1.65 V to 5.5 V.
- Allows down voltage translation.
- Inputs accept voltages to 5.5 V.
- Ioff feature allows voltages on the inputs and outputs when V_{CC} is 0 V.

Device Functional Table

INPUTS		OUTPUT
A	B	Y
L	L	L
L	H	H
H	L	H
H	H	L

IC Application Information

The FLG74LVC1G86 device can accept input voltages up to 5.5 V at any valid V_{CC} which makes the device suitable for down translation. This feature of the SN74LVC1G86 makes it ideal for various bus interface applications. Typical Application

Typical Application

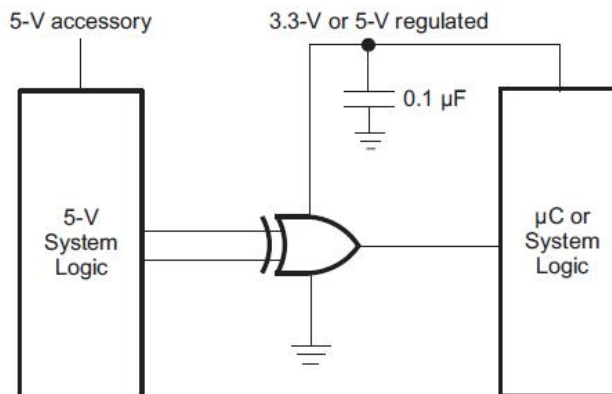

Typical Application Schematic

Design Requirements

This device uses CMOS technology and has balanced output drive. Care should be taken to avoid bus contention because it can drive currents that would exceed maximum limits. The high drive will also create fast edges into light loads so

routing and load conditions should be considered to prevent ringing.

Detailed Design Procedure

1. Recommended Input Conditions

- Rise time and fall time specs. See ($\Delta t / \Delta V$) in the Recommended Operating Conditions table.
- Specified high and low levels. See (V_{IH} and V_{IL}) in the Recommended Operating Conditions table
- Inputs are overvoltage tolerant allowing them to go as high as ($V_I \text{ max}$) in the Recommended Operating Conditions table at any valid V_{CC} .

2. Recommend Output Conditions

- Load currents should not exceed ($I_O \text{ max}$) per output and should not exceed total current (continuous current through V_{CC} or GND) for the part. These limits are located in the Absolute Maximum Ratings table.
- Outputs should not be pulled above V_{CC} .

Application Curves

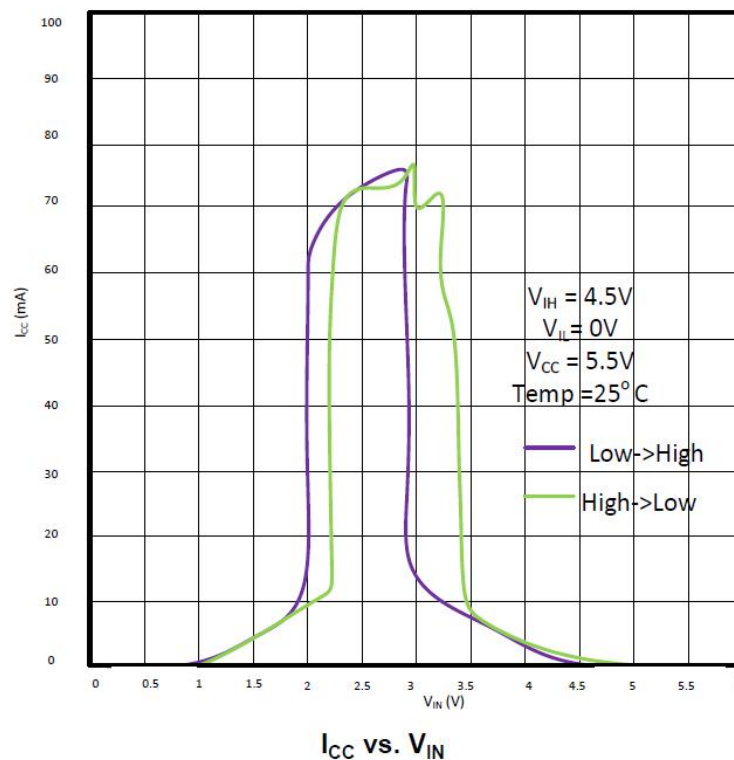

Power Supply Recommendations

The power supply can be any voltage between the min and max supply voltage rating located in the Recommended Operating Conditions table.

Each V_{CC} pin should have a good bypass capacitor to prevent power disturbance. For devices with a single supply, a 0.1- μF capacitor is recommended and if there are multiple V_{CC} pins then 0.01- μF or 0.022- μF capacitor is recommended for each power pin. It is ok to parallel multiple bypass capacitors to reject different frequencies of noise. 0.1- μF and 1- μF

capacitors are commonly used in parallel. The bypass capacitor should be installed as close to the power pin as possible for best results.

Layout Considerations

When using multiple bit logic devices inputs should not ever float. In many cases, functions or parts of functions of digital logic devices are unused; for example, when only two inputs of a triple-input Exclusive-OR gate are used or only 3 of the 4 buffer gates are used. Such input pins should not be left unconnected because the undefined voltages at the outside connections result in undefined operational states. Specified below are the rules that must be observed under all circumstances. All unused inputs of digital logic devices must be connected to a high or low bias to prevent them from floating. The logic level that should be applied to any particular unused input depends on the function of the device. Generally they will be tied to GND or VCC whichever make more sense or is more convenient.

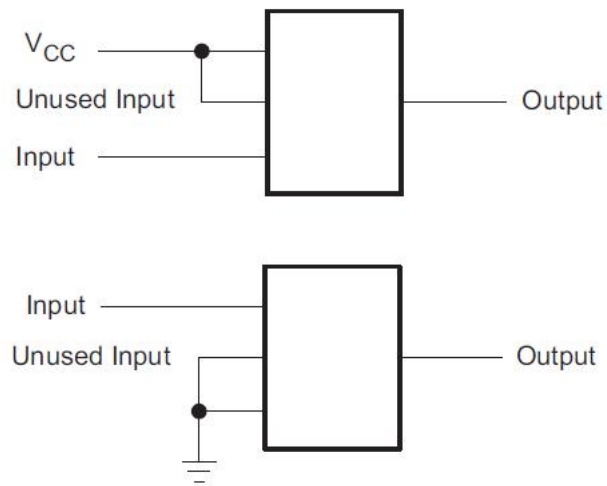

Package Information

(1) Package Type: SOT23-5

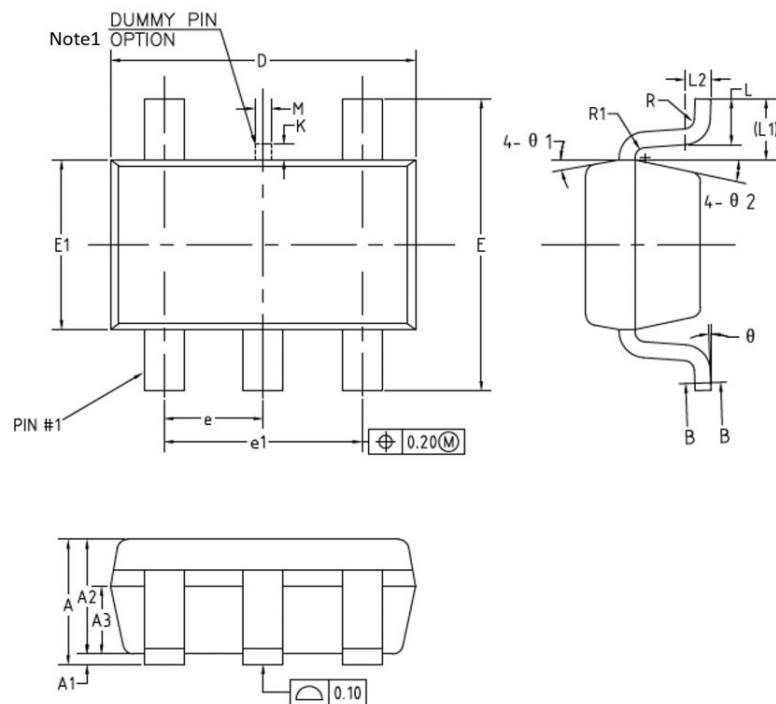

COMMON DIMENSIONS
(UNITS OF MEASURE=MILLIMETER)

SYMBOL	MIN	NOM	MAX
A	—	—	1.25
A1	0	—	0.15
A2	1.00	1.10	1.20
A3	0.60	0.65	0.70
△ b	0.34	—	0.45
△ b1	0.34	0.38	0.41
△ c	0.12	—	0.20
△ c1	0.12	0.15	0.16
D	2.826	2.926	3.026
E	2.60	2.80	3.00
△ E1	1.526	1.626	1.700
e	0.90	0.95	1.00
e1	1.80	1.90	2.00
△ K	0	—	0.20
L	0.30	0.40	0.60
L1	0.59REF		
L2	0.25BSC		
△ M	0.10	0.15	0.20
R	0.05	—	0.20
R1	0.05	—	0.20
θ	0°	—	8°
θ 1	8°	10°	12°
θ 2	10°	12°	14°

Notes: 1. Dummy pin may differ or may not be present.

(2) Package Type: SC70

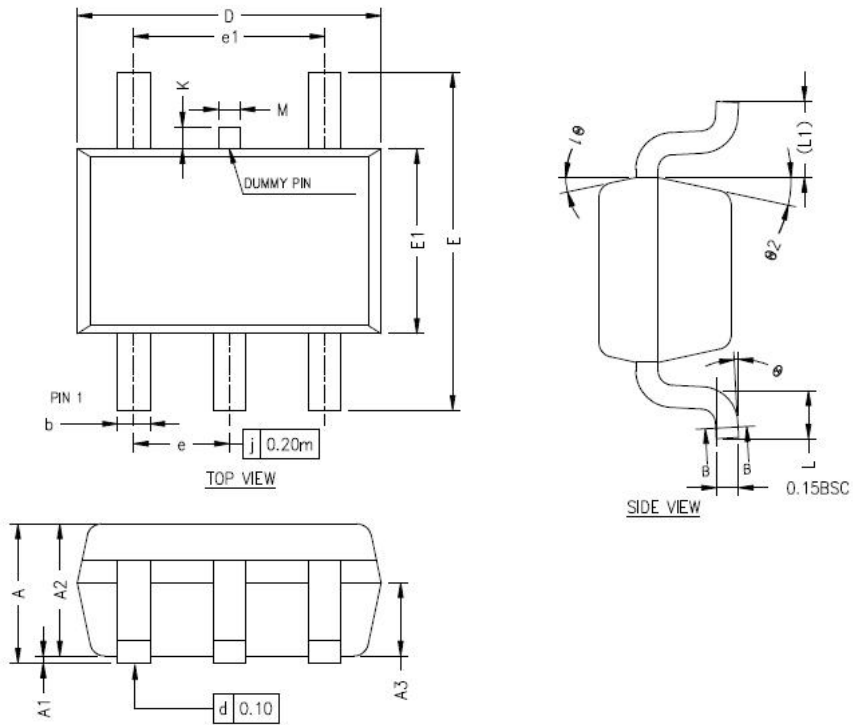

COMMON DIMENSIONS
(UNITS OF MEASURE=MILLIMETER)

SYMBOL	MIN	NOM	MAX
A	0.80	—	1.10
A1	0	—	0.10
A2	0.80	0.90	1.00
A3	0.40	0.50	0.60
b	0.17	—	0.30
b1	0.17	0.22	0.25
\triangle_3 c	0.12	—	0.20
\triangle_3 c1	0.12	0.15	0.16
D	2.02	2.07	2.12
E	2.20	2.30	2.40
E1	1.21	1.26	1.31
e	0.60	0.65	0.70
e1	1.20	1.30	1.40
L	0.26	0.33	0.46
L1	0.52REF		
\triangle_2 M	0.10	0.15	0.20
\triangle_2 K	0	—	0.20
θ	0°	—	8°
θ_1	10°	12°	14°
θ_2	10°	12°	14°

Important Notice And Disclaimer

- We reserves the right to change the instruction manual without prior notice.
- Any semiconductor product has a certain possibility of failure or malfunction under specific conditions. The buyer is responsible for complying with safety standards and taking safety measures when using our products for system design and overall manufacturing to avoid potential failure risks that may cause personal injury or property damage.
- The improvement of product quality is endless, our company will be dedicated to provide customers with better products.