

Four-Channel Differential 2:1 USB 3.1 Super Speed 10Gbps Mux/DeMux

Descriptions

The FSW3820 is a high-speed bidirectional passive switch in mux or demux configurations suited for USB Type-C™ application supporting USB 3.1 Gen 1 and Gen 2 data rates. Based on control pin SEL, the device provides switching on differential channels between Port A or Port B to Port COM. The FSW3820 is a generic analog differential passive switch that can work for any high-speed interface applications requiring a common mode voltage range of 0 to 2 V and differential signaling with differential amplitude up to 1800 mVpp. It employs adaptive tracking that ensures the channel remains unchanged for the entire common mode voltage range. Excellent dynamic characteristics of the device allow high-speed switching with minimum attenuation to the signal eye diagram with very little added jitter. It consumes <2mW of power when operational and has a shutdown mode exercisable by EN Pin resulting <20uW.

Features

- 4-Differential Channel 2:1 Mux/DeMux
- USB 3.1 Super Speed 10Gbps Switch
- High Bandwidth: 10.87GHz @-3dB BW
- Supports both AC coupled and DC coupled signals
- Isolation: -40dB @ 2.0 Gbps
- Crosstalk: -31dB @ 2.0 Gbps
- ESD Tolerance: 2kV HBM
- Low bit-to-bit skew, Bidirectional

Applications

- USB Type-C Ecosystem
- Desktop and Notebook PCs
- Server/Storage Area Networks
- PCI Express Backplanes
- Shared I/O Ports
- FPD LinkII and FPD LinkIII Switching

Order information

Mode	Package	Specified Temperature range	Ordering Number	Packing Option
FSW3820	QFN4x4-32L	-40°C to +85°C	FSW3820YQFN32G/TR	Tape and Reel,5000

Block Diagram

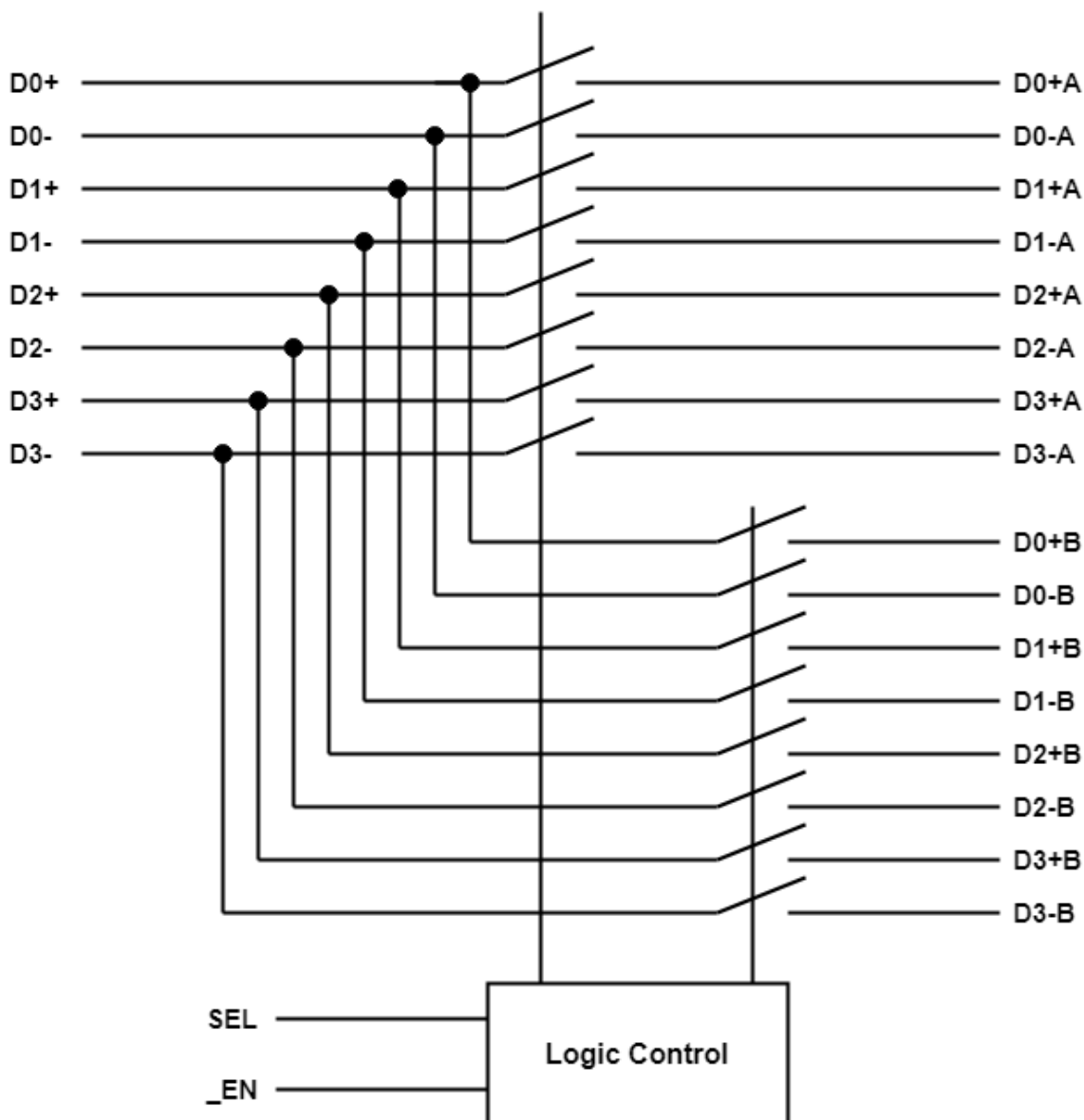

Pin Configuration

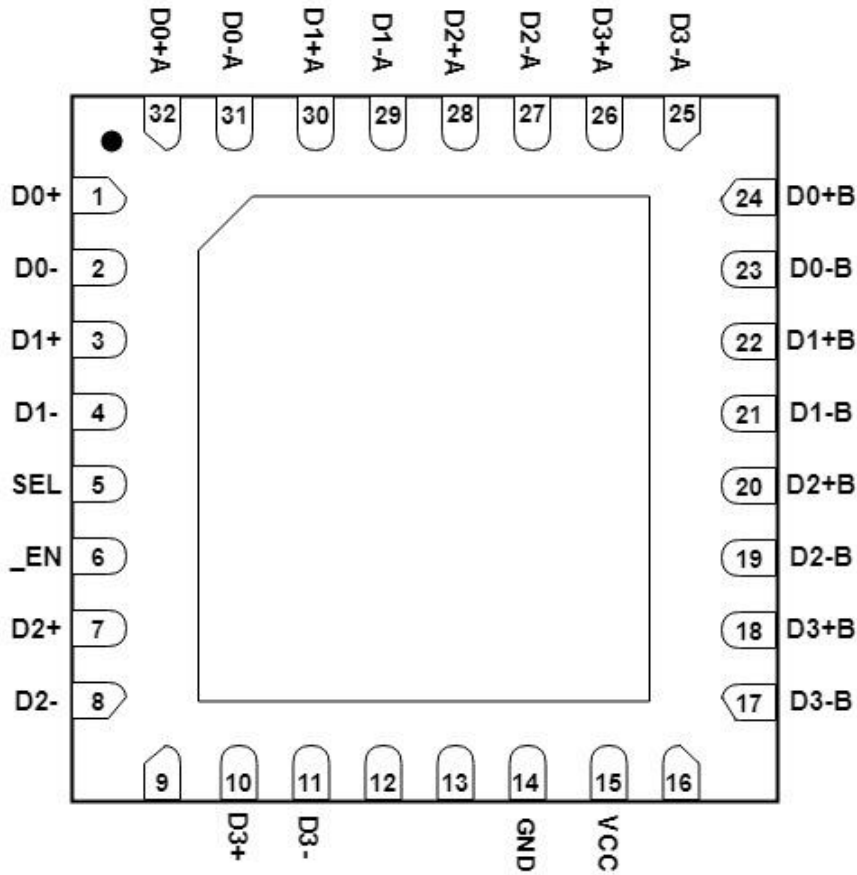

Pin#	Pin Name	Signal Type	Description
1	D0+	I/O	Positive differential signal 0 for COM port
2	D0-	I/O	Negative differential signal 0 for COM port
3	D1+	I/O	Positive differential signal 1 for COM port
4	D1-	I/O	Negative differential signal 1 for COM port
5	SEL	I	Select Pin, See Truth Table
6	_EN	I	Enable Pin,Active Low
7	D2+	I/O	Positive differential signal 2 for COM port
8	D2-	I/O	Negative differential signal 2 for COM port
9	NC	/	Not Connected
10	D3+	I/O	Positive differential signal 3 for COM port
11	D3-	I/O	Negative differential signal 3 for COM port
12	NC	/	Not Connected
13	NC	/	Not Connected
14	GND	Ground	Power Ground
15	VCC	Power	Positive Supply Voltage
16	NC	/	Not Connected
17	D3-B	I/O	Negative differential signal 3 for port B
18	D3+B	I/O	Positive differential signal 3 for port B
19	D2-B	I/O	Negative differential signal 2 for port B
20	D2+B	I/O	Positive differential signal 2 for port B

21	D1-B	I/O	Negative differential signal 1 for port B
22	D1+B	I/O	Positive differential signal 1 for port B
23	D0-B	I/O	Negative differential signal 0 for port B
24	D0+B	I/O	Positive differential signal 0 for port B
25	D3-A	I/O	Negative differential signal 3 for port A
26	D3+A	I/O	Positive differential signal 3 for port A
27	D2-A	I/O	Negative differential signal 2 for port A
28	D2+A	I/O	Positive differential signal 2 for port A
29	D1-A	I/O	Negative differential signal 1 for port A
30	D1+A	I/O	Positive differential signal 1 for port A
31	D0-A	I/O	Negative differential signal 0 for port A
32	D0+A	I/O	Positive differential signal 0 for port A

Truth Table

<u>EN</u>	SEL	Dx+/-
High	X	Hi-Z
Low	Low	Dx+/-A
Low	High	Dx+/-B

Note:x=0,1,2,3

Maximum Ratings

(Above which useful life may be impaired. For user guidelines, not tested.)

Storage Temperature	-65°C to +150°C
Junction Temperature	125°C
Supply Voltage to Ground Potential	-0.5V to +5.5V
Supp Speed Data Channel TX / RX	-0.5V to 3.8V
DC Input Voltage	-0.5V to VCC
DC Output Current	50mA
Power Dissipation	300mW

Notes:

Stresses greater than those listed under MAXIMUM RATINGS may cause permanent damage to the device. This is a stress rating only and functional operation of the device at these or any other conditions above those indicated in the operational sections of this specification is not implied. Exposure to absolute maximum rating conditions for extended periods may affect reliability.

Electrical Characteristics

(TA=25°C, VCC=1.8V, unless otherwise specified)

Parameter	Symbol	conditions	Min.	Typ.	Max	Unit
POWER SUPPLY						
VCC Quiescent Current	I _Q	SEL=0 or VCC, <u>EN</u> =0		28		uA
Power-down Current	I _{PO}	SEL=0 or VCC, <u>EN</u> =VCC			1	uA
DC CHARACTERISTICS						
Input logic high	V _{IH}	VCC=1.8~4.5V	1.6			V
Input logic low	V _{IL}	VCC=1.8~4.5V			0.4	V
<u>EN</u> Internal pull-up resistor	R _{UP}			2		MΩ
SEL Internal pull-down resistor	R _{DN}			2		MΩ

On-Resistance for TX/RX	R_{ON_HS}	$V_{IS} = 0.2V$ $I_{ON} = 8mA$	6.7	8	Ω
R_{ON} Flatness for TX/RX	R_{FLAT_LP}	$V_{IS} = 0$ to $1.2V$ $I_{ON} = 8mA$	0.8	1	Ω
R_{ON} Flatness for TX/RX	R_{FLAT_LP}	$V_{IS} = 0$ to $0.2V$ $I_{ON} = 8mA$	0.2	0.3	Ω
R_{ON} Matching Between Channels	R_{MATCH}	$V_{IS} = 0$ to $1.2V$ $I_{ON} = 8mA$	0.1		Ω
AC CHARACTERISTICS					
Enable Time _EN to Output	t_{EN}	$R_L = 50\Omega$ $C_L = 0pF$ $V_{IS} = 0.6V$	80	150	μS
Disable Time _EN to Output	t_{DIS}	$R_L = 50\Omega$ $C_L = 0pF$ $V_{IS} = 0.6V$	40	250	nS
Turn-On Time SEL to Output	t_{ON}	$R_L = 50\Omega$ $C_L = 0pF$ $V_{IS} = 0.6V$	400	1200	nS
Turn-Off Time SEL to Output	t_{OFF}	$R_L = 50\Omega$ $C_L = 0pF$ $V_{IS} = 0.6V$	130	800	nS
Break-Before-Make Time	t_{BBM}	$R_L = 50\Omega$ $C_L = 0pF$ $V_{IS} = 0.6V$	250	800	nS
Propagation Delay	t_{PD}	$R_L = 50\Omega$ $C_L = 0pF$ $V_{IS} = 0.6V$	0.25		nS
Off Isolation	Off	$R_L = 50\Omega$ $f = 1.2GHz$ $V_{IS} = 0.2V_{PP}$, See Fig.2	-27		dB
Crosstalk	X_{TALK}	$R_L = 50\Omega$ $f = 1.2GHz$ $V_{IS} = 0.2V_{PP}$, See Fig.1	-43		dB
-3dB Bandwidth	BW_{-3dB}	$R_L = 50\Omega$ $C_L = 0pF$ Signal 0dBm	10.87		GHz
CAPACITANCE					
Switch On Capacitance	C_{ON}	$V_{Bias} = 0.2V$, $f = 1.5GHz$	1.5		pF
Switch Off Capacitance	C_{OFF}	$V_{Bias} = 0.2V$, $f = 1.5GHz$	1.0		pF

Notes:

- (1) Flatness is defined as the difference between maximum and minimum value of ON-resistance at the specified analog signal voltage points.
- (2) R_{ON} matching between channels is calculated by subtracting the channel with the lowest max Ron value from the channel with the highest max Ron value.
- (3) Crosstalk is inversely proportional to source impedance

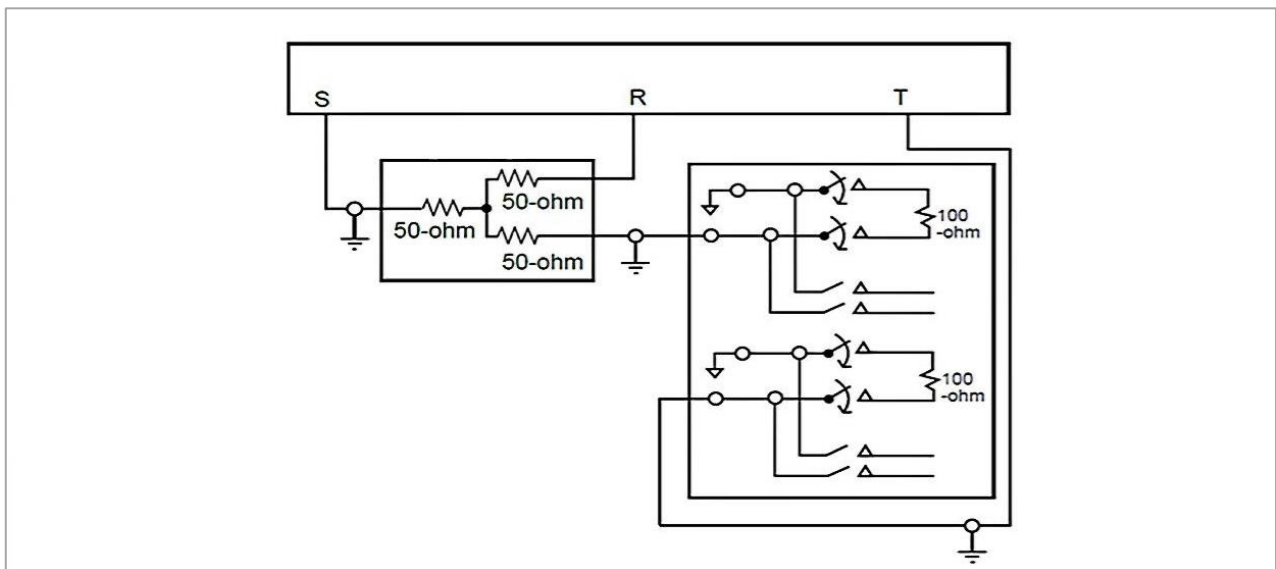

Fig.1 Crosstalk Setup

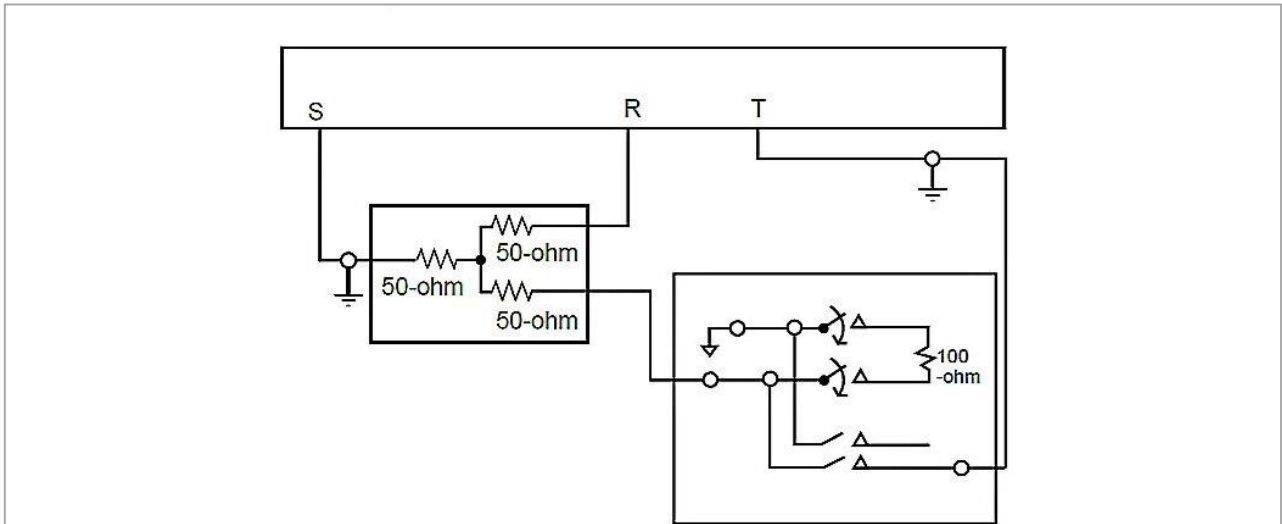

Fig.2 OFF-isolation

Application Information

Many interfaces require AC coupling between the transmitter and receiver. The 0402 capacitors are the preferred option to provide AC coupling, and the 0603 size capacitors also work. The 0805 size capacitors and C-packs should be avoided. When placing AC coupling capacitors symmetric placement is best. A capacitor value of 0.1 μF is best and the value should be match for the \pm signal pair. The placement should be along the TX pairs on the system board, which are usually routed on the top layer of the board.

There are several placement options for the AC coupling capacitors. Because the switch requires a bias voltage, the capacitors must only be placed on one side of the switch. If they are placed on both sides of the switch, a biasing voltage should be provided. A few placement options are shown below. In Figure 1, the coupling capacitors are placed between the switch and endpoint. In this situation, the switch is biased by the system/host controller.

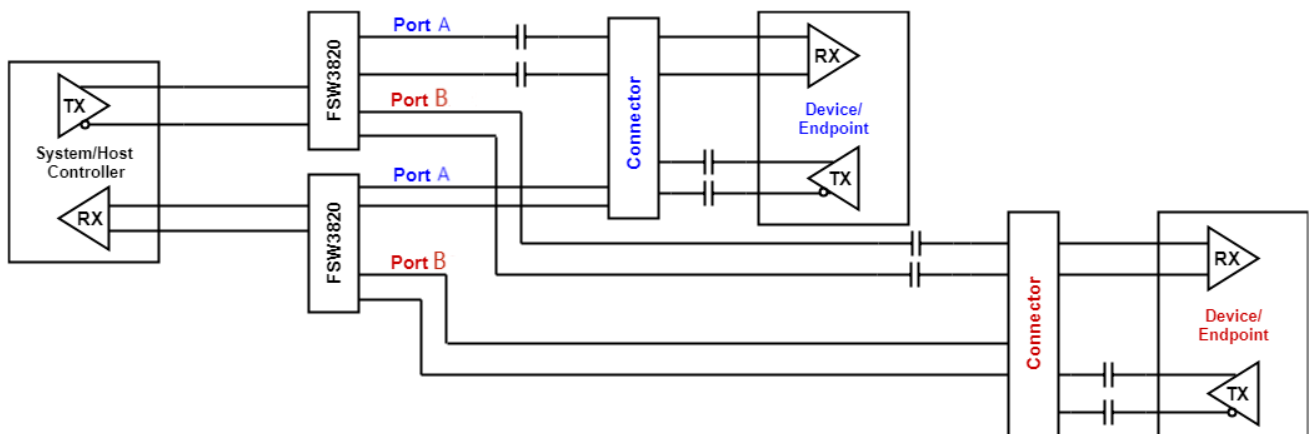

Figure 1. AC Coupling Capacitors Between Switch Tx and Endpoint Tx

In Figure 2, the coupling capacitors are placed on the host transmit pair and endpoint transmit pair. In this situation, the switch on the top is biased by the endpoint and the lower switch is biased by the host controller.

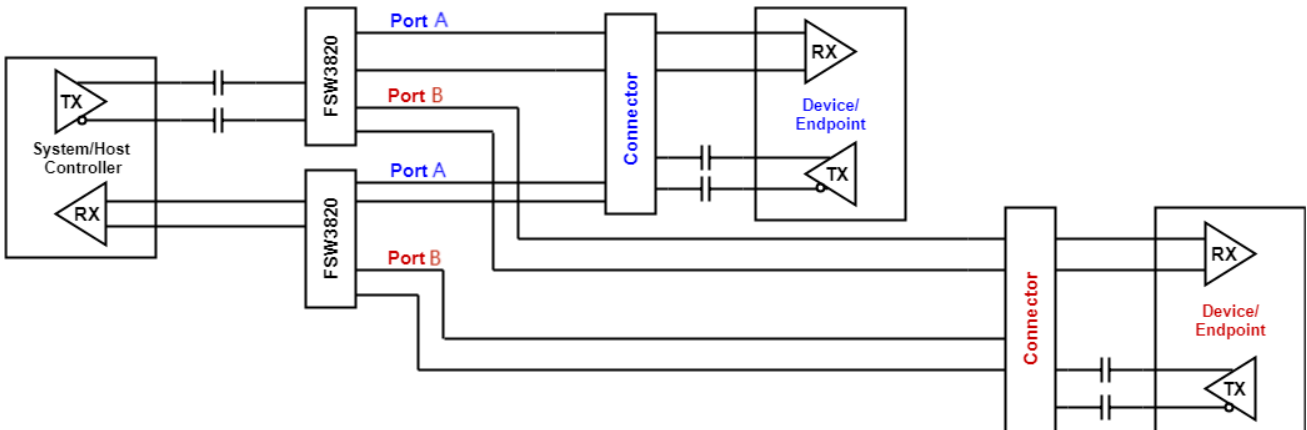

Figure 2. AC Coupling Capacitors on Host Tx and Endpoint Tx

If the common-mode voltage in the system is higher than 2V, the coupling capacitors are placed on both sides of the switch (shown in Figure 3). A biasing voltage of less than 2V is required in this case.

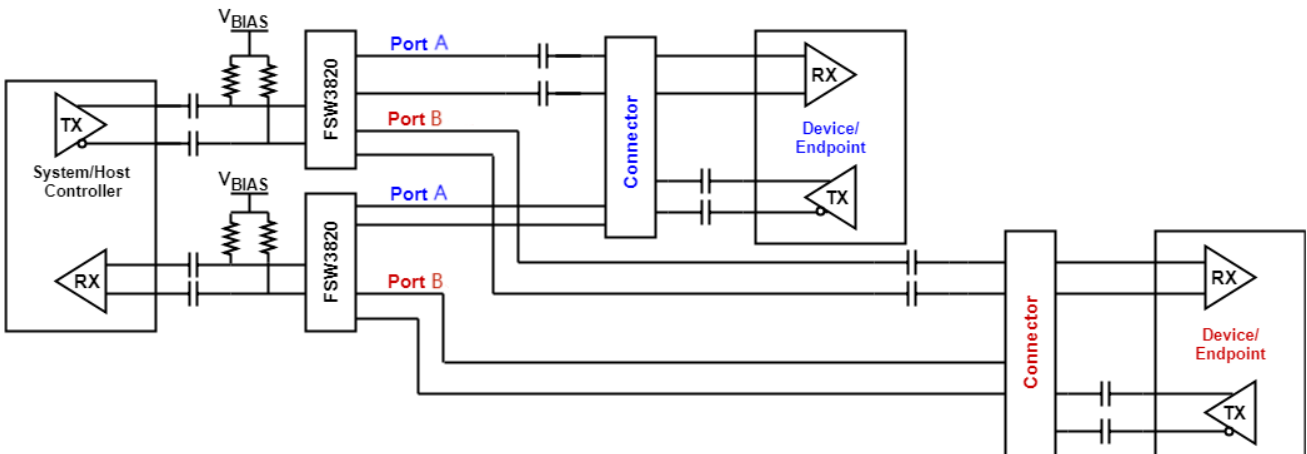
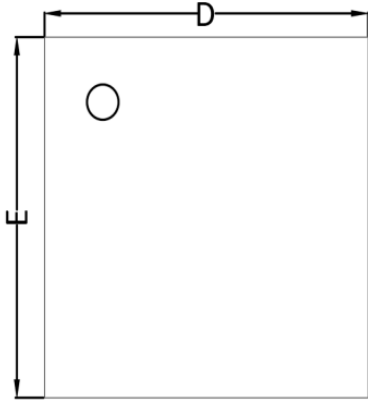

Figure 3. AC Coupling Capacitors on Both Sides of Switch

Package Outline Dimensions(All dimensions in mm.)

(1) Package Type: QFN4x4-32L



TOP VIEW

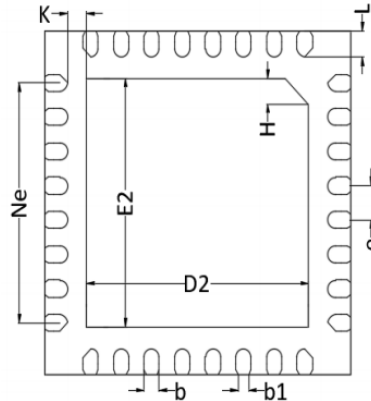

BOTTOM VIEW

COMMON DIMENSIONS (UNITS OF MEASURE=MILLIMETER)			
SYMBOL	MILLIMETER		
	MIN	NOM	MAX
A	0.50	0.55	0.60
A1	0.00	0.02	0.05
A2	0.152 REF		
D	3.90	4.00	4.10
E	3.90	4.00	4.10
D2	2.80	2.90	3.00
E2	2.80	2.90	3.00
Ne	2.80 BSC		
e	0.40 BSC		
H	0.30 REF		
L	0.25	0.30	0.35
K	0.20	0.25	0.30
b	0.15	0.20	0.25
b1	0.14REF		

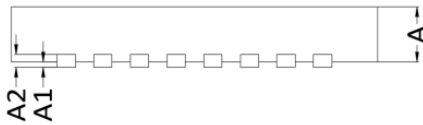

SIDE VIEW

(2) Top Marking Information

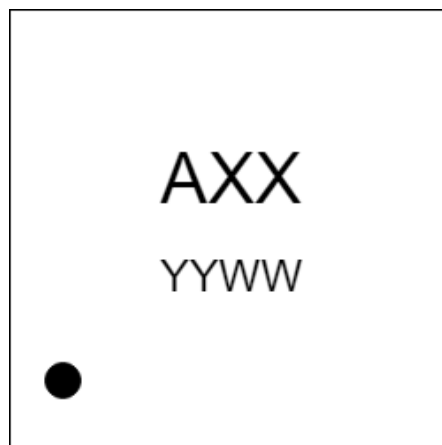

YY: Year (23=2023,24=2024...)

WW: Weekly (01-53)

AXX: Internal ID Code

TAPE AND REEL INFORMATION

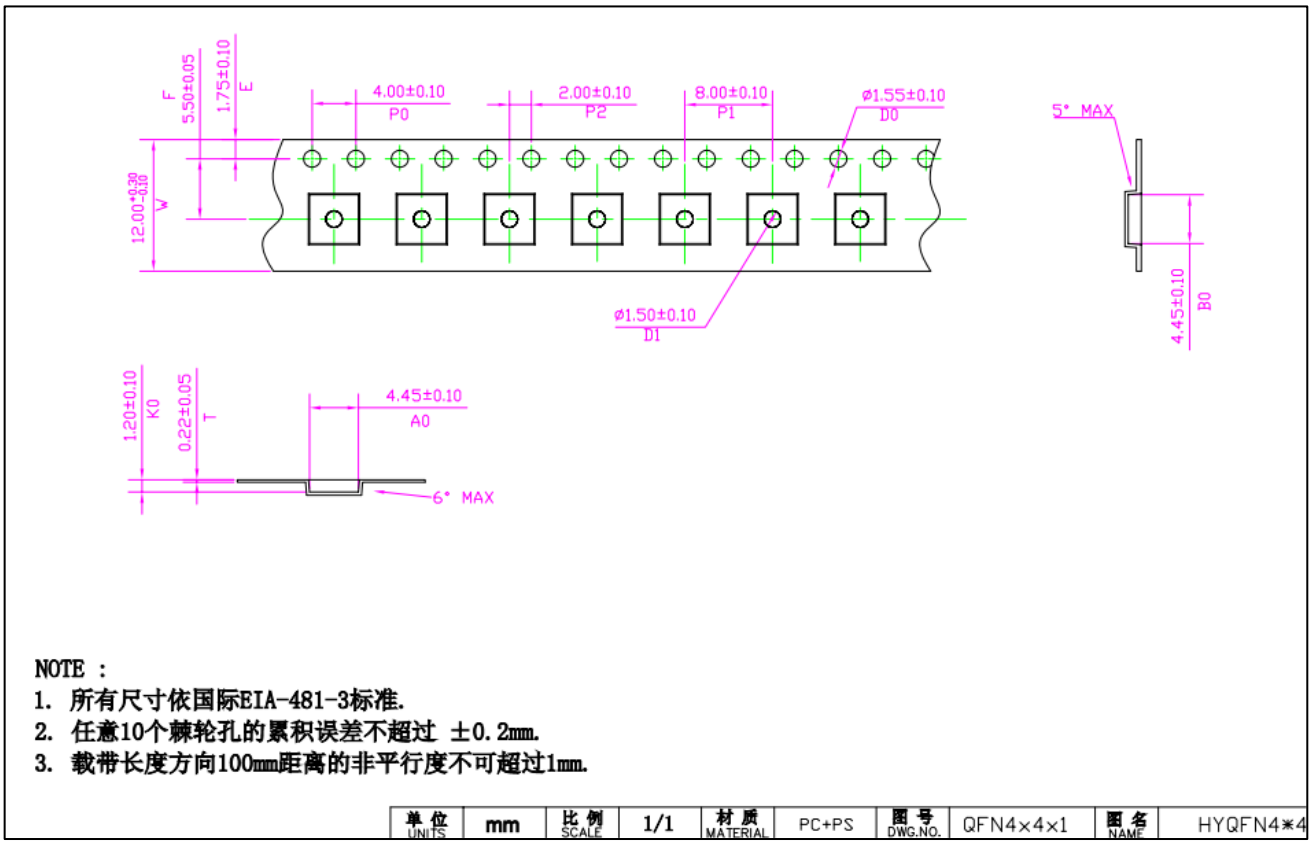
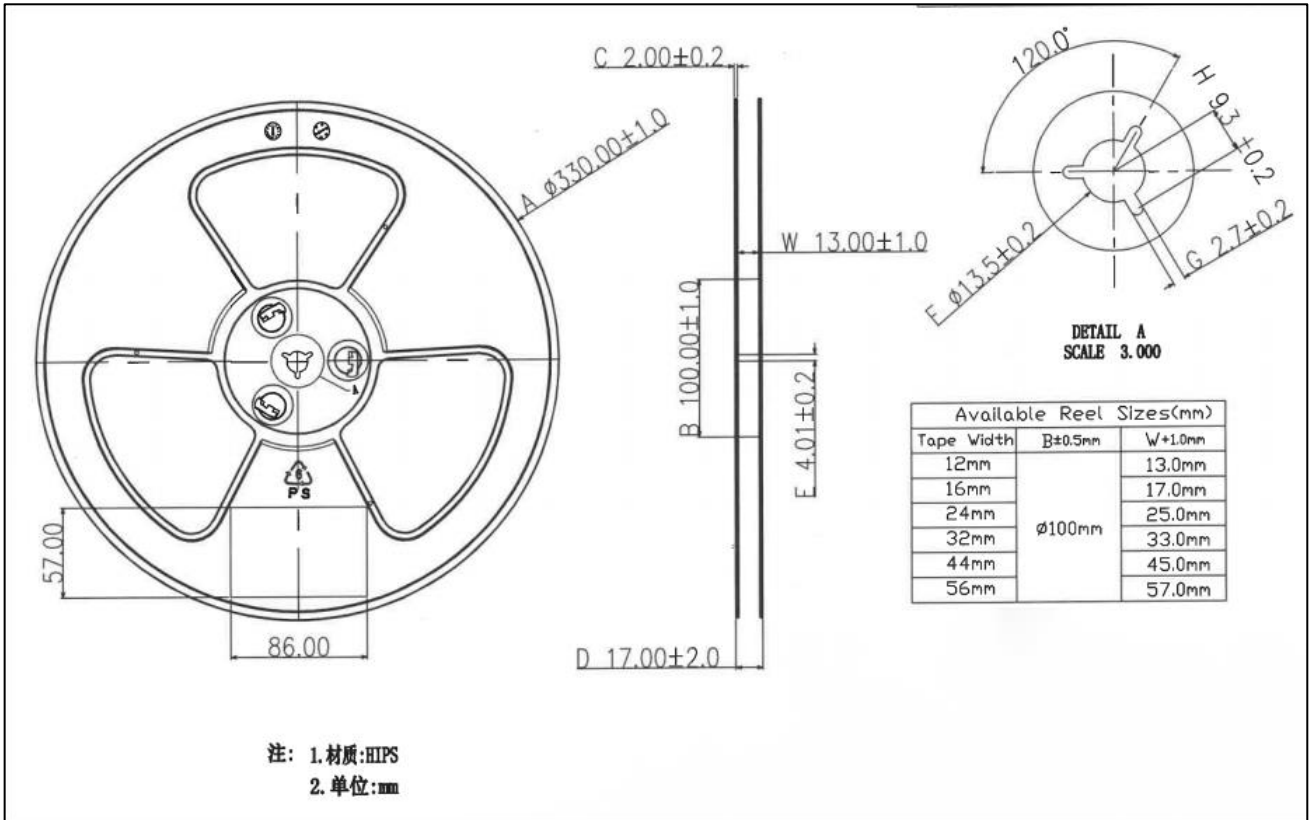

Version Modification Record

Version Number	Revision	Date
first edition		2023/10/26
V1.0	Update package as QFN4X4-32L	2023/12/08